

TCA-DEL

Low Level Split Automatic

The TCA-DEL is a front line fully automatic split wheel bin lift with the following key features:

- **Efficiency**, fast automatic cycle time of 7 seconds plus dwell time, which can be adjusted between 0.5-1.5 sec.
- **Flexibility**, because the TCA-DEL is a genuine low level bin lift it offers a hand loading access height of approx. 1.2 m.
- **Low weight**, the TCA-DEL weighs only 695 kg
- **Safety**, the unique Terberg geometry means that containers do not kick back towards operators as they are lifted, so that the safety arms conform to EN1501.1 and are user friendly and unobtrusive.
- **Practical operation**, increased ground clearance coupled with automatic reverse raise means that the TCA-DEL is as invulnerable to damage as it is possibly can be.
- **Automatic Shaker**, an adjustable automatic bin shaker allows 'sticky' materials such as grass cuttings to be handled with ease.
- **Diagnostics**, a text display is mounted in a durable box on the side of each bin lift to provide simple fault diagnosis in order to minimise down time.
- **Construction**, the bin lift chairs are constructed from box section steel, so that in the unfortunate event of damage it is often possible to straighten and repair existing components to save time and expense.
- **Waterproof**, the electrical system is located in a waterproof box tested to IP67 submarine standards.



- **Trade containers**, at the turn of a switch the TCA-DEL can be changed over into manual 'trade' mode to lift the full range of four wheeled containers including Paladin bins fitted with conversion bars, cycle time manual trade 12 sec.



The unobtrusive, EN1501-1 conforming side guards make the TCA-DEL extremely operator friendly



The diagnostic system with text display allows easy fault correction to minimise down time

The compact service box contains the hydraulic system and the electrical system sealed in an IP67 waterproof box.



TCA-DEL



Control: Automatic, EN 840.1 (80 - 360 ltr containers).
 Manual, EN 840.1 (340 - 390 ltr containers with a width greater than 61 cm).
 EN 840.2 (500 - 1200 ltr containers).
 EN 840.3 (770 - 1300 ltr containers).

Option: Paladin Bins fitted with conversion bars.

Power: Electric / Hydraulic.
 Electric; 24V DC, 10A.
 Hydraulic; minimum 40 L.min., maximum 60 L.min., Pressure 180 bar.

Lifting capacity: 1000N/5000N (100 kg/500 kg).

Weight: 695 kg.

Cycle time: Automatic 7.0 sec. plus dwell (0.5-1.5 sec.).
 Manual split 7.0 sec. / Manual Trade 12.0 sec.

Noise level: ≤ 65 dB (A)

Safety: CE Machinery Directive certification and EN 1501.1 conformity.

Connections: Quick release hydraulic couplings (DIN 2353, NW13, NW20)
 and 16 pin electrical connection.

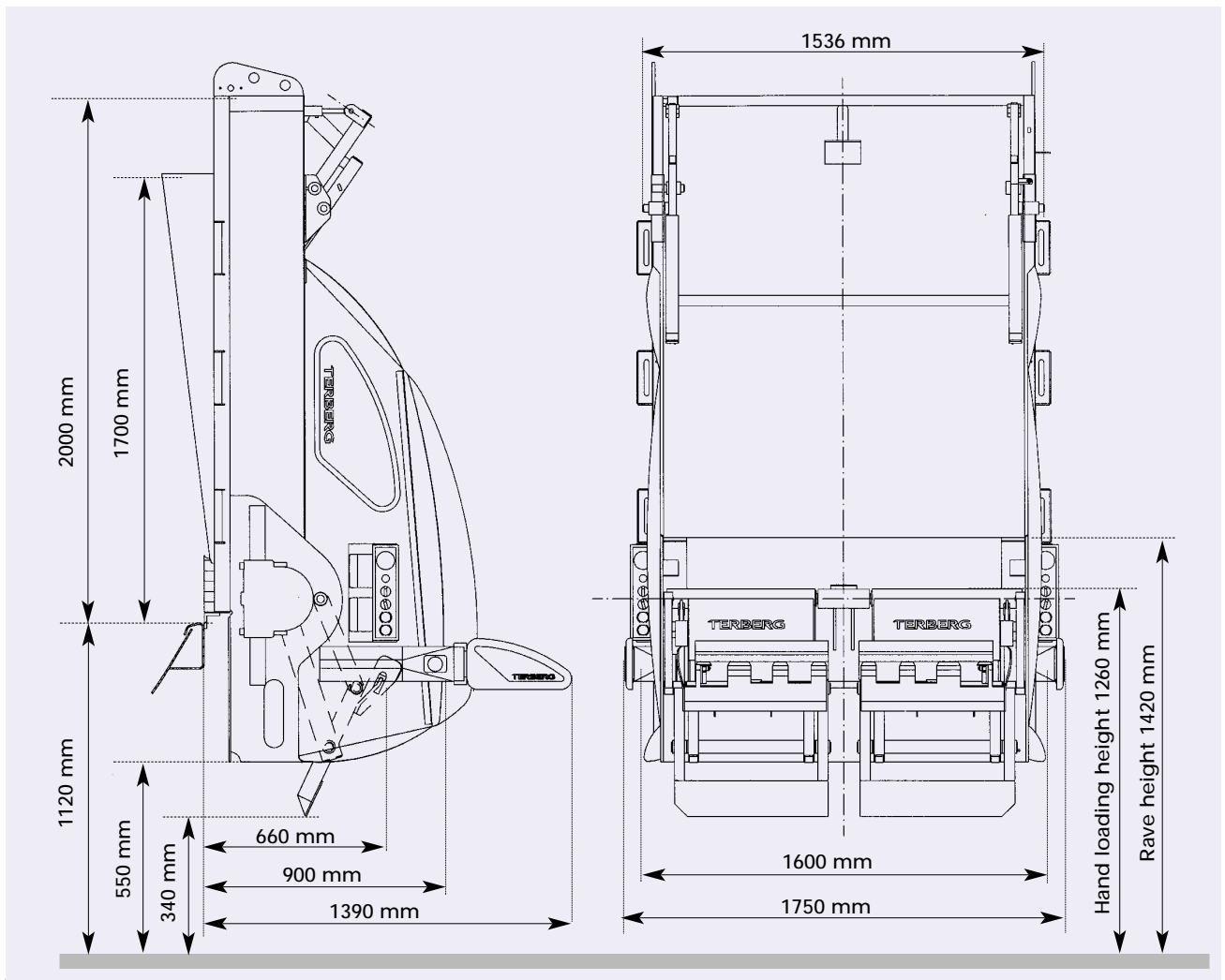

We reserve the right to change the specification of our equipment at any time without prior notification.



TERBERG MACHINES B.V.
 P.O. box 23, 3400 AA IJsselstein (U) The Netherlands
 Phone. (31) 30 688 1944 / Fax (31) 30 688 5523
 E-mail: info@terbergmachines.nl

