

## TA-DE

### High Level Split Automatic

The TA-DE is a front line fully automatic split wheel bin lift with the following key features;

- **Efficiency**, fast automatic cycle time of 8 sec. plus dwell time, which can be adjusted between 0,5-3 seconds.
- **Trade containers**, at the turn of a switch the TA-DE can be changed over into manual 'trade' mode to lift the full range of four wheeled containers including Paladin bins fitted with conversion bars, cycle time manual trade 13 sec.
- **Low weight**, the TA-DE weighs only 730 kg.
- **Safety**, the unique Terberg geometry means that containers do not kick back towards operators as they are lifted, enabling that the safety arms whilst conforming to EN1501.1 to be user friendly and unobtrusive.
- **Practical operation**, exceptional ground clearance coupled with automatic reverse raise means that the TCA-DE is an invulnerable to damage as it is possible to be.
- **Automatic Shaker**, an adjustable automatic bin shaker allows 'sticky' materials such as grass cuttings to be handled with ease.
- **Packing Cycle Delay Control**, to take full advantage of the high mounting height and subsequent increase hopper volume, the TA-DE can be pre set to cycle after a set number of bin lift cycles.
- **Diagnostics**, a text display is mounted in a durable box on the side of each bin lift to provide simple fault diagnosis in order to minimise down time.
- **Construction**, the bin lift chairs are constructed from box section steel, so that in the unfortunate event of collision damage it is often possible to straighten and repair existing components to save time and expense,
- **Waterproof**, the electrical system is located in a waterproof box tested to IP67 submarine standards.



Gemakkelijk bereikbaar hydrauliekblok

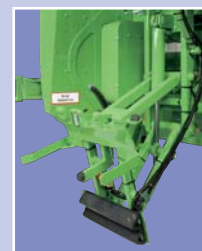

Opneemstoel met zijgeleiding voor het snel en goed positioneren van de container op de opneemkam



Overzichtelijk bedienings-paneel en gemakkelijk bereikbare noodstopknop

## TA-DE



**Control:** Automatic, EN 840.1 (80 - 340 ltr containers).

**Power** Electric / Hydraulic.  
 Electric; 24V DC, 10A.  
 Hydraulic; minimum 40 L.min., maximum 60 L.min., Pressure 180 bar.

**Lifting capacity:** 1000N (100 kg).

**Weight:** 730 kg.

**Cycle time:** Automatic 7,0 sec. (0,5-1,5 sec.).

**Noise level:** ≤ 65 dB (A)

**Safety:** CE Machinery Directive certification and EN 1501.1 conformity.

**Connections:** Quick release hydraulic couplings (DIN 2353, NW13, NW20) and 16 pin electrical connection.

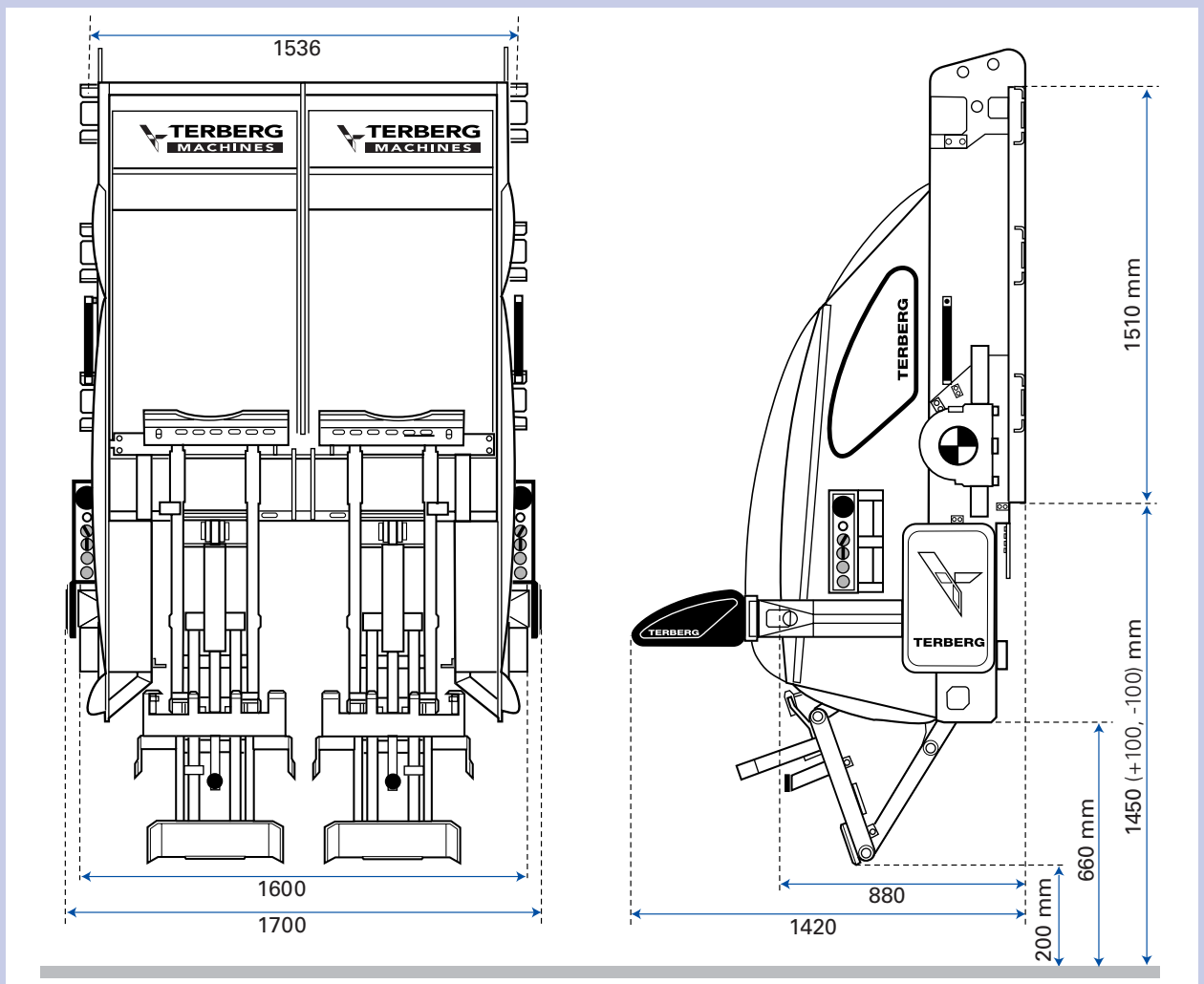

We reserve the right to change the specification of our equipment at any time without prior notification.



**TERBERG MACHINES B.V.**

P.O. box 127, 3400 AC IJsselstein (U) The Netherlands

Phone. (31) 30 2100 600 / Fax (31) 30 2100 610

E-mail: [info@terbergmachines.nl](mailto:info@terbergmachines.nl) / [www.terbergmachines.nl](http://www.terbergmachines.nl)

TA-DE eng./ned. 11-003